

JEFFERSON COUNTY PURCHASING DEPARTMENT  
HISTORIC COURT HOUSE, 195 ARSENAL STREET  
WATERTOWN, NEW YORK 13601-2565  
PH: (315) 785-3077  
FAX: (315) 785-7591  
Email: [Purchasing@co.jefferson.ny.us](mailto:Purchasing@co.jefferson.ny.us)

Date of Notice: August 3, 2023

Notice to Bidders

In accordance with Section 103 of General Municipal Law, State of New York, Jefferson County (herein called the County) invites the submission of sealed bids for:

**BID #23-33 BOILER REPLACEMENT AT THE JEFFERSON COUNTY HUMAN SERVICES BUILDING**

Bids will be received by the County until **THURSDAY, AUGUST 24, 2023 AT 3:30 PM EST.**, at the office of the Purchasing Department, 195 Arsenal Street, Watertown, New York 13601. Bids may not be submitted via fax or email, and all bids submitted must remain valid for up to forty-five (45) days from the date of the bid opening. No bids will be considered if received after the due date and time and the Purchasing Department shall assume no responsibility for the premature opening of any bid not properly addressed and identified.

Copies of this bid may be examined and copies obtained at the County Purchasing Department. The County reserves the right to reject any and all bids received.

All questions regarding this bid should be submitted in writing (mail, fax, or email) to the County Purchasing Department.

**A MANDATORY SITE VISIT HAS BEEN SCHEDULED FOR MONDAY, AUGUST 14, 2023 AT 10:00AM EST., MEETING AT THE SECURITY DESK OF THE JEFFERSON COUNTY HUMAN SERVICES BUILDING, 250 ARSENAL STREET, WATERTOWN, NY. PLEASE CONTACT THE COUNTY PURCHASING DEPARTMENT AT 315-785-3077 TO CONFIRM YOUR ATTENDANCE.**

## INSTRUCTIONS TO BIDDERS & GENERAL REQUIREMENTS

1. With submission of a bid, a Bidder agrees to be bound by the requirements set forth in the following general conditions. Whenever reference is made to “Contractor”, “Bidder”, or “Vendor”, this shall include the party with whom the County has entered into an agreement, as well as any subcontractors whom the Bidder has engaged. Please submit two (2) copies - one (1) original unbound and one (1) copy.
2. The County does not assume responsibility for errors or misinterpretations resulting from the use of incomplete sets of documents or documents that were not directly issued by the Jefferson County Purchasing Department. Any Vendor submitting a bid based on incomplete or inaccurate information resulting from documentation received from a third party shall not have cause for relief or completion of a contract in accordance with the official documents on file with the Purchasing Department. Verbal explanations or instructions regarding this bid provided by anyone other than an employee of the Purchasing Department shall be considered informal and will not be binding on the County unless confirmed in writing as an amendment to this solicitation, if such information is deemed necessary for the preparation of uniform bids. The County reserves the right to “Revise” or “Amend” the bid specification prior to the bid opening date by “Written Addenda”  
Prior to submission of a bid it is the responsibility of each Bidder to become fully familiar with the requirements of this solicitation. No Bidder may plead misunderstanding because of the misinterpretation of estimates, scope of work, or other issues related to this request. It shall be the responsibility of each Bidder to identify any apparent discrepancy in the specifications or question of interpretation thereof. Failure to do so constitutes acceptance as written. The apparent silence of this specification as to any details or the omission from it of a detailed description concerning any part shall be interpreted as meaning that only the best commercial practices are to prevail and that only materials and workmanship of first quality are to be used. The County shall have the right to waive any technical defect, qualification, omission, informality, or irregularity in any bid received if, in its judgment, the best interest of the County shall thereby be served. **The County will issue no response to any request for clarification received within seven (7) days of the due date.**
3. Bids should be submitted in a sealed envelope marked with the name of the bid and the words “**SEALED BID**” written on the outside of the envelope. Please submit two (2) copies - one (1) original unbound and one (1) copy. No employee in the Purchasing Department will be held liable for the premature opening of any bid received not designated as such. Bids submitted by **FAX OR E-MAIL** will not be accepted.
4. Taxes. No charge will be allowed for federal, state, sales, and excise taxes from which the County is exempt. Exemption Certificates will be provided upon request.
5. Deviations. Deviations to the specifications must be fully explained, and if judged to be in the best interest of the County, may be accepted at the sole discretion of the County.
6. Qualifications. Each Bidder must be prepared to present satisfactory proof of his ability to successfully complete the requirements of this solicitation.  
The County reserves the right to make whatever investigations or inquiries necessary to determine the competency and ability of any Bidder to complete the requirements of this solicitation. A review may include but not be limited to inspection of the Bidder’s facilities and equipment, references or previous contract performance with the County or others.
7. Accountability - Bidder shall be fully accountable for his or her performance under any contract executed pursuant to this solicitation, and agrees to answer under oath all questions relevant to the performance thereof as to any transaction, or action done or omitted in connection therewith if called before any Judicial, County or State Office or Agency empowered to investigate the contract or performance. By submitting a bid, the bidder affirms that all the requirements of the specifications are understood and accepted, and prices quoted shall be considered all-inclusive except as noted.

Each bidder affirms that all figures provided are correct to the best of their knowledge and understands that Jefferson County will not be responsible for any errors or omissions on the part of the bidder regarding estimates, calculations, or preparation of the bid, and will not be grounds for withdrawal or correction of the bid or bid security except as provided under General Municipal Law. In case of errors between unit and extension of prices, the unit price will govern.

8. Award. The County has endeavored to incorporate within these specifications all the elements which it reasonably anticipates will be required to obtain responses from qualified Bidders. By submission of a bid you agree to provide goods or services consistent with these specifications unless otherwise stated. The bid will be awarded to the lowest responsive and responsible Bidder meeting the specifications or providing acceptable deviation.

The County reserves the right to reject in whole or part, any or all bids deemed not to be in the best interest of the County at the sole discretion of the County. If two or more Bidders submit identical bids as to price, the decision of the County to award a contract to one of such Bidders shall be final. If, after review it is determined that both bids are essentially equivalent the names of both bidders will be placed in a container and the winning bid selected by a draw witnessed by a minimum of two members of the Purchasing Department and a member of the County Audit department. The resulting contract award shall be deemed executory only to the extent of the monies appropriated and available, and no liability on account thereof shall be incurred by the County beyond the amount of such monies. It is understood that neither this contract nor any representation by any public employee or office creates any legal or moral obligation to request, appropriate or make available monies for the purpose of the contract.

The County intends to issue a formal Purchase Order to purchase the goods and/or services described in this solicitation. The Terms and Conditions that govern all Purchase Orders issued by Jefferson County are available on the Purchasing Department link of the County's Website at [www.co.jefferson.ny.us](http://www.co.jefferson.ny.us).

It is understood that the successful Contractor is an independent Contractor and shall not be considered an agent of the County, nor shall any of the Contractor's agents or employees be considered subagents for the County.

**PLEASE NOTE THAT THE COUNTY WILL NOT PROVIDE VERBAL RESULTS OF ANY BID. REQUESTS FOR BID RESULTS MUST BE SUBMITTED IN WRITING (EMAIL IS ACCEPTABLE) TO THE JEFFERSON COUNTY PURCHASING DEPARTMENT AT [purchasing@co.jefferson.ny.us](mailto:purchasing@co.jefferson.ny.us) RESPONSES WILL BE PROVIDED AS SOON AS POSSIBLE.**

9. Disqualification

The County reserves the right to reject any proposal for any of the following reasons:

- Failure to satisfy the requirements of this Bid.
- Failure to settle outstanding bills for labor or materials related to previous contracts with the County.
- The Bidder defaulted under previous contracts with the County.
- If it is determined that the Bidder is already obligated for the performance of other work which would delay the commencement, prosecution, or completion of the services required.
- Lack of sufficient personnel, assets, or financial resources necessary to provide the services successfully as revealed by either financial statements or experience.
- Evidence of Collusion among Bidders.
- The Bidder cannot satisfy the County as to ability to perform.

10. New York State Wage Rates. If any portion of work being bid is subject to the prevailing wage rate provisions of the NYS Labor Law, the successful bidder is responsible for complying with all current labor rates and regulations throughout the duration of any contract resulting from this bid and will





<u>Type of Coverage</u>	<u>MINIMUM Limits of coverage</u>
Workers' Compensation and NYS Disability	Statutory
Business Automobile Liability (Combined Bodily Injury and Property Damage arising out of the ownership, operation, use, loading or unloading of all owned, leased, hired and non-owned vehicles)	\$1,000,000 Combined Single Limit
Commercial General Liability, (including Broad form contractual Liability, combined bodily injury and property damage)	\$1,000,000 Each Occurrence \$2,000,000 General Aggregate Limit \$2,000,000 Products-Completed Operations \$1,000,000 Advertising/Personal Injury \$5,000 Premises Medical Payment

Each policy of insurance required herein shall be specifically endorsed to provide that in the event of cancellation, non-renewal, or material change on the part of the insurer, prior written notice shall be provided to COUNTY in accordance with the terms of the CONTRACTOR'S policy. The inclusion of such endorsement shall be confirmed on the certificates of insurance required herein.

At the time of execution of this Agreement, and upon each policy renewal, CONTRACTOR shall submit to COUNTY certificates of insurance evidencing CONTRACTOR's compliance with the requirements of this Section, including certificates of insurance from any approved subcontractors. The CONTRACTOR shall furnish the appropriate ACORD Form Certificate of Insurance to COUNTY to evidence all coverage set forth above except Workers' Compensation and Disability Insurance. **A copy of the additional insured and waiver of subrogation endorsement forms must be submitted with the insurance certificates.**

Workers' Compensation coverage must be evidenced by Form C105.2 or New York State Insurance Fund Form U26.3. Disability Insurance coverage must be evidenced by Form DB120.

#### **REQUIRED EXTENDED REPORTING COVERAGE FOR CLAIMS BASED POLICIES**

In the event that CONTRACTOR'S Commercial General Liability Policy is a "claims made" policy, and coverage thereunder is cancelled or otherwise not renewed, and such policy is not replaced with another "claims made" Commercial General Liability Policy which provides continuing, uninterrupted coverage, CONTRACTOR shall be required to purchase extended reporting products-completed operations coverage for a minimum of three (3) years after completion of all work required of CONTRACTOR under this Agreement.

#### **REQUIRED MINIMUM RETROACTIVE DATE FOR CLAIMS BASED POLICIES**

In the event that CONTRACTOR'S Commercial General Liability Policy is a "claims made" policy, the retroactive date for products-completed operations coverage under such policy must be at least one (1) year prior to the commencement date of this Agreement and must be shown on the appropriate ACORD Form Certificate of Insurance furnished to COUNTY.

12. Indemnification. CONTRACTOR agrees to indemnify, defend and hold harmless COUNTY, and its officers, employees and agents from and against any and all claims, liens, demands, judgments, penalties, fines, liabilities, settlements, damages, costs and expenses of whatever kind or nature (including, without limitation, attorneys' fees and disbursements), known or unknown, contingent or otherwise, whether incurred as a result of a claim by a third party or any other person or entity, arising out of or in any way related to: (a) the work or operations of CONTRACTOR in the performance of this Agreement; or (b) CONTRACTOR'S failure to comply with any of the provisions of this Agreement or of the Law. Insofar as the facts and Law relating to any claim would preclude COUNTY or its officers, employees or agents, from being completely indemnified by CONTRACTOR, COUNTY and its officers,

employees and agents, shall be partially indemnified by CONTRACTOR to the fullest extent permitted by Law. The acts or omissions of any party employed directly or indirectly by CONTRACTOR, shall be deemed to be that of CONTRACTOR for the purposes of the CONTRACTOR's obligations to defend, indemnify and hold harmless under this Section. The fact that a party so employed by CONTRACTOR is alleged to or is proven to have acted outside the scope of employment, agency or contract, shall not relieve CONTRACTOR of any of its duties under this Section.

13. **Contract Term and Renewal Option.** The initial contract term shall be from **Date of Award until Final Completion and Acceptance by the County.**
14. **Contract Cancellation.** Unless otherwise noted, the County of Jefferson retains the right to cancel any contract without cause provided the Vendor is given at least thirty (30) days notice of intent to cancel. This provision should not be understood as waiving the County's right to terminate the contract for cause or stop work immediately for unsatisfactory work, but is supplementary to that provision. The County may cancel a contract for any of, but not limited to the following:
- If a pattern develops where a vendor consistently fails to deliver product or services which do not meet the original specifications of the award
  - It is determined that gratuities in the form of entertainment, gifts, or otherwise were offered or given by a Vendor, his agent, or representative to any County official or employee with intent toward securing favorable treatment with respect to the award of a contract or the performance of an agreement
  - It is determined that the successful bidder engaged in any other illegal or improper scheme promotive of favoritism or unfairness incidental to the solicitation process or the performance of the agreement
  - It is determined that said improper or illegal acts occurred, the County shall be entitled to terminate any agreement and/or exercise any other remedy available to it under existing law.

In the event of any termination, postponement, delay, suspension, or abandonment the Vendor shall deliver to the County all data, reports, plans, or other documentation related to the performance of the contract, including, but not limited to guarantees, warranties, plans, and shop drawings. In any of these events the County shall make settlement with the Vendor upon an equitable basis as determined by the County and shall fix the value of the work which was performed by the Vendor prior to the postponement, suspension, abandonment, or termination of the contract.

15. Pursuant to the provisions of Section 109 of the General Municipal Law, no Bidder to whom a contract is granted or awarded shall assign, transfer, convey, subcontract, or otherwise dispose of all or part of such contract, or of his right, title, and interest herein, including the performance of the contract or the right to receive monies due, or to become due, or of his power to execute the contract without the prior written consent of the Jefferson County Purchasing Department.

Prior to submitting a subcontractor for approval, bidder shall diligently inquire into the capability, qualifications, and background of the subcontractor, and the submission of a subcontractor for approval shall constitute an affirmative representation by the bidder that the subcontractor is fully capable, qualified, and licensed to provide the subcontracted services. Any subcontract entered into by the bidder pursuant to this bid shall provide that the bidder will retain ultimate control and responsibility for the service provided under the subcontract and that the subcontractor shall be bound by the provisions of the agreement between the bidder and the County and any other requirements applicable shall be deemed to exist between any subcontractor and the County, nor shall the bidder be relieved of any of the bidder's obligations under this contract, as a consequence of any subcontract approved by the County.

In the event the Bidder shall, without prior written consent, assign, transfer, convey, subcontract or otherwise dispose of the contract, or of his right, title, and interest herein, including the performance of the contract, or the right to receive monies due, or to become due, or his power to execute such contract, to any other person or corporations or upon receipt by Jefferson County of an attachment against the Bidder, the County of Jefferson shall be relieved and discharged from any and all liability and obligation growing out of such contract to such Bidder and the person or corporation to which

such contract shall have been assigned, his assignees, transferees, or sublessee shall forfeit and lose all monies theretofore assigned on this contract, except so much as may be required to pay his employees.

16. The Successful Bidder agrees to comply with any and all applicable laws, codes, and regulations in connection with the goods and services called for in this bid as well as the non-discrimination and employment practices as required by applicable State and Federal laws and regulations regarding employment discrimination. The bidder assures the County that in accordance with applicable law: it does not and agrees that it will not discriminate in any manner on the basis of age, color, creed, national origin, race, religious beliefs, sexual preference or handicap.
17. Audit. The County, or its duly authorized agent, shall have access to and copies of the Contractor's records, including any books, electronic media, or programs, or material pertaining to work performed under the contract, at no cost to the County, to determine and verify the compliance with all contractual conditions. The County shall be granted access to such records at all reasonable times during the contract period and for three (3) years thereafter.
18. FOIL. Submission of a bid or proposal to Jefferson County shall be deemed consent for the proposal to be publicly identified, and the information contained therein shall be deemed a matter of public record unless such information is designated by the party submitting the bid or proposal as trade secrets or other information allowed to be kept confidential pursuant to the Public Officers' Law of the State of New York.

All material submitted in response to this Bid becomes the property of the County and will be considered public records after the award of the contract. Proposals shall not be shared with any competing offerors during the selection phase of this procurement; however, after award of the contract to the successful offeror, proposals received in response to this Request for Proposal may be subject to disclosure under a provision of the Freedom of Information Act. Information in proposals that is clearly identified as proprietary will not be disclosed at any time. Blanket statements that all contents of the proposal are confidential and proprietary will not be honored by the County. The New York State Freedom of Information Law (FOIL), as set forth in Public Officers Law, Article 6, mandates public access to certain government records. Generally, proposals submitted in response to this Bid may constitute government records subject to FOIL. Proposals may contain, among other things, certain technical, financial, or other data and information that constitute trade secrets, if publicly disclosed, could cause substantial injury to the commercial enterprise's competitive position. To protect this information from disclosure under FOIL, Proposers should specifically identify the pages of the proposal that contain such information by properly marking the top of the applicable pages as "CONFIDENTIAL" and inserting the following statement in the front of its proposal:

The information or data on pages \_\_\_\_\_ of this proposal, identified on the top thereof as "CONFIDENTIAL", contain financial, technical, or other information which constitute government records subject to FOIL. Proposals may contain, among other things, certain technical, financial, or other data and information that constitute trade secrets, if publicly disclosed, could cause substantial injury to the commercial enterprise's competitive position. We request that the County use such information only for the evaluation of this proposal but we understand that the Authority must comply with the provisions of the New York State Freedom of Information Law (FOIL) and public disclosure of the information contained in this proposal whether or not marked as "CONFIDENTIAL", and to make no claim for any damages as a result of any such disclosure by the County pursuant to FOIL.

In the event the County receives a FOIL request for disclosure of information marked as "CONFIDENTIAL", the Proposer shall be notified of the request and may expeditiously submit a detailed statement and explanation indicating the reasons the Proposer has for believing that the information requested is exempt from disclosure under the law. This detailed statement and explanation shall be used by the County in making its determination as to whether disclosure is required under the law.

"When submitting a bid for consideration, unless otherwise noted, all bidders understand that Jefferson County may reject all submissions that are marked "confidential" either substantially or in their entirety (other than narrowly defined data considered a 'trade secret'. All submissions are considered non public information until the evaluation is complete and a Contract or Purchase Order is issued. At that point all submissions become public record."

19. Equivalency. In submitting a proposal, the Bidder is agreeing to provide goods and services consistent with the specifications. Where a brand name or equivalent specification is used in this solicitation, the use of any brand name noted is for the purpose of describing the standard of quality, performance and characteristics desired and is not intended to limit or restrict competition.

A Contract, if awarded, will be on the basis of materials and equipment as described in the Drawings, or the Specifications, and "or equal" items submitted by the Bidder and accepted by the County. The Bidder may offer "or equal" items that meet the same performance or reliability standards as specified herein. If the Bidder offers an "or equal" item, the Bidder must include with the bid package, documentation establishing equality of construction, operation and utility. Said "or equal" items shall be accepted or rejected based upon the County's evaluation of the submitted documentation. All costs associated with the review of any "or equal" items prior to recommendation to award, shall be at the Bidder's expense.

If a submitted "or equal" item is rejected, the Bidders shall be afforded an opportunity to meet with the County to offer additional qualifying opinions and information prior to the County rejecting the bid. The Bidder shall not have the opportunity to submit any alternative materials or equipment after the bids are opened.

The decision to accept or reject an "or equal" item rests solely with the County. If a substitute "or equal" item is not accepted by the County, the bid will be deemed non-responsive and the County shall reject this bid. The next lowest responsive bid shall then be reviewed for recommendation of award.

20. Jefferson County may access contract pricing available through New York State contracts, GSA Schedule 70, Schedule 84, and Schedule 1122 contracts, and may "piggyback" on some contracts let by other municipal governments. If your products or services are offered through one of these sources you may offer the pricing of the alternate contract already in place.

If at any time during the term of this contract the successful vendor also has a NYS, GSA, or other contract legally available to the County through General Municipal Law, the County reserves the right to purchase from any or all of the contracts and the vendor agrees to supply goods or services in accordance with that contract if requested to do so.

21. Force Majeure: Except for the County's obligation to make payment for goods and/or services delivered hereunder, neither party hereto shall be liable for any failure to perform the terms of the contract when such failure is due to "force majeure" as hereinafter defined. The term "force majeure" as employed in this specification shall mean acts of God, strikes, lockouts, or industrial dispute or disturbances, civil disturbances, arrests and restraint from rulers or people, interruption by government or court orders, present and future valid orders of any regulatory body having proper jurisdiction, acts of the public enemy, wars, riots, blockades, insurrections, inability to secure or a delay in securing labor or materials, including delay in securing or inability to secure materials by reason of allocations promulgated by authorized governmental agencies, epidemics, landslides, lightning, earthquakes, fires, storms, floods, washouts, explosions, inability to obtain easements or right-of-way.

The "force majeure" shall, so far as possible, be remedied with a reasonable dispatch. The settlement of strikes or lockouts or industrial disputes or disturbances shall be entirely within the discretion of the party having the difficulty and the above requirement that any "force majeure" shall be remedied with all reasonable dispatch shall not require the settlement of strikes, lockouts, or industrial disputes or disturbances by acceding to the demands of any opposing party therein when such course is inadvisable in the discretion of the parties having the difficulty.

22. Site Visit. All Contractors must attend the site visit at the same time. Contractors should attend a site visit to become familiar with any local conditions that may in any manner affect the work to be done, as well as equipment, materials, labor, or services required. Contractors are required to carefully examine the specifications and to familiarize themselves thoroughly with regards to any and all conditions and requirements of the installation. During the site visit, Contractors may specify if there are any necessary modifications or additions to the site, which are required. No allowances will be made because of lack of knowledge of these conditions. Ignorance of the requirements does not relieve the Contractors of their liability and obligations under these contracts.

A Mandatory Site Visit of the project will be conducted by the County and has been scheduled for **MONDAY, AUGUST 14, 2023, at 10:00AM EST.** Please contact the Jefferson County Purchasing Department at 315-785-3077 to confirm your attendance.

23. Iranian Energy Sector Divestment. Contractor hereby represents that said Contractor is in compliance with New York State General Municipal Law Section 103-g entitled “Iranian Energy Sector Divestment”, in that said Contractor has not:
- a. Provided goods and services of \$20 Million or more in the energy sector of Iran including but not limited to the provision of oil or liquified natural gas tankers or products used to construct or maintain pipelines used to transport oil or liquified natural gas for the energy sector of Iran; or
  - b. Acted as a financial institution and extended \$20 Million or more in credit to another person for forty-five days or more, if that person’s intent was to use the credit to provide goods or services in the energy sector in Iran.

Any Contractor who has undertaken any of the above and is identified on a list created pursuant to Section 165-a (3)(b) of the New York State Finance Law as a person engaging in investment activities in Iran, shall not be deemed a responsible Bidder pursuant to Section 103 of the New York State General Municipal Law.

Except as otherwise specifically provided herein, every Contractor submitting a bid in response to this Request for Bids must certify and affirm the following under penalties of perjury:

- a. “By submission of this bid, each Bidder and each person signing on behalf of any Bidder certifies, and in the case of a joint bid, each party thereto certifies as to its own organization, under penalty of perjury, that to the best of its knowledge and belief, that each Bidder is not on the list created pursuant to NYS Finance Law Section 165-a (3)(b).”

Jefferson County will accept this statement electronically in accordance with the provisions of Section 103 of the General Municipal Law.

Except as otherwise specifically provided herein, any Bid that is submitted without having complied with subdivision (a) above, shall not be considered for award. In any case where the Bidder cannot make the certification as set forth in subdivision (a) above, the Bidder shall so state and shall furnish with the bid a signed statement setting forth in detail the reasons therefore. The County reserves its rights, in accordance with General Municipal Law Section 103-g to award the Bid to any Bidder who cannot make certification, on a case-by-case basis under the following circumstances:

1. The investment activities in Iran were made before April 12, 2012, the investment activities in Iran have not been expanded or renewed after April 12, 2012, and the Bidder has adopted, publicized and is implementing a formal plan to cease the investment activities in Iran and to refrain from engaging in any new investments in Iran; or
2. The County of Jefferson has made a determination that the goods or services are necessary for the County to perform its functions and that, absent such an exemption, the County of Jefferson would be unable to obtain the goods or services for which the Bid is offered. Such a determination shall be made by the County in writing and shall be a public document.

24. ARTICLE 15-A (M/WBE-EEO Goals)

Pursuant to Article 15-A of the Executive Law, New York State requires minimum project participation of 20% by Minority- or Woman-Owned Business Enterprise(s), or M/WBEs. If the Vendor/Consultant is not a New York State certified Minority- or Woman-Owned Business Enterprise, the Vendor/Consultant may be asked to provide a clear outline of how they propose to meet or exceed these M/WBE goals. Jefferson County promotes and encourages Minority or Woman-Owned Business to participate in the BID Process. The County reserves the right to reject any response that does not meet the requirement of the funding source.

Upon demand by the County the Contractor must provide the following:

1. Documentation of efforts to extend opportunities through advertisement in minority/women trade association newsletters and/or minority/women owned media.
2. Documentation showing that minority/women contractor associations, including the local MBE/WBE Office were notified of the subcontracting to be let.
3. Documentation showing that the work to be subcontracted was segmented to the extent consistent with the size and capability of minority/women owned firms.
4. Copies of solicitation letters inviting quotes or proposals from MBE and WBE firms.
5. Documentation of good faith negotiations with MBE and WBE firms from whom responses were received in an effort to reach a mutually acceptable price.
6. Any other relevant documentation, which demonstrates the Contractor's good faith efforts to achieve the MBE/WBE participation goals of this Contract.

25. Sexual Harassment. By submission of this bid, each bidder and each person signing on behalf of any bidder certifies, and in the case of a joint bid each party thereto certifies as to its own organization, under penalty of perjury, that the bidder has and has implemented a written policy addressing sexual harassment prevention in the workplace and provides annual sexual harassment prevention training to all of its employees. Such policy shall, at a minimum, meet the requirements of section two hundred one-g of the labor law. Where competitive bidding is not required, state departments and agencies may, at their discretion, require the above certification. A model policy and training has been created by the NYS Department of Labor and can be found here: <https://www.ny.gov/programs/combating-sexual-harassment-workplace>

26. Fuel Surcharge. The County shall consider the implementation of a fuel surcharge as a result of a national or worldwide catastrophe that causes the "Weekly US On-Highway Diesel Fuel Price" for the Central Atlantic (New York State) region to exceed 1.5 times the price per gallon at the time of bid opening. For example, if the price at the time of Bid Opening is \$4.00 a gallon; the price per gallon would have to exceed \$6.00 a gallon before Jefferson County would consider implementing a fuel surcharge.

**BOILER REPLACEMENT AT THE JEFFERSON COUTNY HUMAN SERVICES BUILDING**  
**BID #23-33**  
**DETAILED SPECIFICATIONS**

Jefferson County is seeking bids from qualified contractors to furnish and install a replacement boiler at the Jefferson County Human Services Building, 250 Arsenal Street, Watertown, NY 13601, as per the following specifications:

One (1) ea – New, Unused H.B. Smith Model #19HE-S-10 (or equivalent) Steam Boiler with Power Flame and Controls to match existing “sister” boiler at this facility. Specification sheets are included in Attachment A.

Complete Installation of above referenced boiler to include, but not limited to:

- Fabrication and installation of new steam risers and header; modify/fabricate header to allow 2<sup>nd</sup> boiler to operate independently as well as simultaneously; installation of new gas train and piping; installation of new control panels, conduit, wiring, insulation, and fittings. Reinstall building management system controls removed from existing boiler.
- Existing boiler and all materials will be removed and disposed of by County personnel.
- Start boiler & test safety operating controls according to manufacturer's specifications. Provide Jefferson County with all operation and Maintenance manuals, wiring diagrams, schematics, as built, warranty documents and final inspection reports. Return system to service.
- There will be a Mandatory site visit for contractors to assess the location, obtain the proper specifications, understand the existing conditions, determine all work and materials necessary and develop a plan to perform the installation of all the required equipment necessary for a successfully finished project.

It is the contractor’s responsibility to familiarize themselves with the extent of the work to be performed and any conditions that may in any manner affect to the work to be done and the equipment, materials, and labor required for a fully operational system. The site visit has been scheduled for: **Monday, August 14, 2023, at 10:00AM EST.**

All vendors must submit a minimum of three (3) references from completed projects of similar size and complexity.

**BOILER REPLACEMENT AT THE JEFFERSON COUTNY HUMAN SERVICES BUILDING**

**BID #23-33**

**BID PAGE**

H.B SMITH MODEL #19HE-S-10 (OR EQUIVALENT) STEAM BOILER \$ \_\_\_\_\_

FREIGHT (IF APPLICABLE) \$ \_\_\_\_\_

INSTALLATION MATERIAL/ EQUIPMENT COST \$ \_\_\_\_\_

LABOR COST FOR COMPLETE INSTALLATION \$ \_\_\_\_\_

TOTAL PROJECT COST \$ \_\_\_\_\_

LEAD TIME / AVAILABILTY OF BOILER \_\_\_\_\_

INSTALLATION TIMEFRAME AFTER RECEIPT OF BOILER \_\_\_\_\_

**PLEASE NOTE: BIDS FROM ANY VENDOR WHO HAS NOT ATTENDED THE MANDATORY WALK THROUGH/SITE VISIT WILL NOT BE CONSIDERED**

**COMPANY NAME:** \_\_\_\_\_ **DATE:** \_\_\_\_\_



**BID PROPOSAL CERTIFICATIONS**

Firm Name: \_\_\_\_\_

Business Address: \_\_\_\_\_

Telephone Number: \_\_\_\_\_ Fax Number: \_\_\_\_\_

Email: \_\_\_\_\_ Federal ID Number: \_\_\_\_\_

I. General Bid Certification

The bidder certifies that he will furnish, at the prices herein quoted, the materials, equipment, and/or services as proposed on this bid.

Any deviation to specifications is fully explained and attached. By signing and submitting this bid for consideration to the County of Jefferson, the vendor acknowledges that they have read, understand, and agree to the specifications as presented without reservation or alteration.

Deviations: Yes \_\_\_\_\_ No \_\_\_\_\_

II. Non-Collusive Bidding Certification

By submission of this bid proposal, the bidder certifies that he is complying with Section 103-d of the General Municipal Law as follows:

Statement of non-collusion in bids and proposals to political subdivision of the state. Every bid or proposal hereafter made to a political subdivision of the state or any public department, agency or official thereof where competitive bidding is required by statute, rule, regulation, or local law, for work or services performed or to be performed or goods sold or to be sold, shall contain the following statement subscribed by the bidder and affirmed by such bidder as true under the penalties of perjury: Non-collusive bidding certification.

A. By submission of this bid, each bidder and each person signing on behalf of any bidder certifies, and in the case of a joint bid each party thereto certifies as to its own organization, under penalty of perjury, that to the best of its knowledge and belief:

- (1) The prices in this bid have been arrived at independently without collusion, consultation, communication or agreement, for the purpose of restricting competition, as to any matter relating to such prices with any other bidder or with any competitor.
- (2) Unless otherwise required by law, the prices which have been quoted in this bid have not been knowingly disclosed by the bidder and will not knowingly be disclosed by the bidder prior to opening, directly or indirectly, to any other bidder or to any competitor; and
- (3) No attempt has been made or will be made by the bidder to induce any other person, partnership or corporation to submit or not submit a bid for the purpose of restricting competition.

B. A bid shall not be considered for award nor shall any award be made where A. (1)(2) and (3) above have not been complied with; provided, however, that if in any case the bidder shall so state and shall furnish with the bid a signed statement which set forth in detail the reasons therefore. Where A.(1)(2) and (3) above have not been complied with, the bid shall not be considered for award nor shall any award be made unless the head of the purchasing unit of the political subdivision, public department, agency or official thereof to which the bid is made, or his designee, determines that such disclosure was not made for the purpose of restricting competition.

- (1) The fact that a bidder (a) has published price lists, rates, or tariffs covering items being procured, (b) has informed prospective customers of proposed or pending publication of new or revised price lists for such items, or (c) has sold the same items to other customers at the same prices being bid, does not constitute, without more, a disclosure within the meaning subparagraph one (a).

Printed Name of Signer \_\_\_\_\_  
Authorized Signature \_\_\_\_\_  
Title \_\_\_\_\_  
Date \_\_\_\_\_

**NON-BIDDER'S RESPONSE**

For purposes of maintaining accurate Bidder's lists and facilitating your firm's response to our invitation for bid, the County of Jefferson is interested in ascertaining reasons for prospective Bidder's failure to respond to invitations for bids. If your firm is not responding to this bid, please indicate the reason(s) by checking any appropriate item(s) below and returning this form to the Jefferson County Purchasing Director, 195 Arsenal Street, Watertown, New York 13601. This form may be returned by mail or fax. Faxes may be sent to 315-785-7591. Failure to submit either a bid proposal or return this form will result in removal of your firm's name from our Bidder's lists. Thank you for your cooperation.

We are not responding to this invitation for bid for the following reason(s)

- Items or materials requested not manufactured by us or not available to our company.
- Our items or materials do not meet specifications.
- Specifications not clearly understood or applicable (too vague, too rigid, etc.)
- Quantities too small.
- Insufficient time allowed for preparation of bid.
- Incorrect address used. Correct mailing address is:

\_\_\_\_\_

\_\_\_\_\_

\_\_\_\_\_

- Our branch/division handles this type of bid. Correct name and mailing address is:

\_\_\_\_\_

\_\_\_\_\_

\_\_\_\_\_

- We are unable to bid at this time but would like to continue to receive invitations for bids.
- We are unable to bid and wish to be removed from the Bidder's list.

NAME OF FIRM: \_\_\_\_\_

MAILING ADDRESS: \_\_\_\_\_

CITY/STATE/ZIP CODE: \_\_\_\_\_

BY: \_\_\_\_\_

Signature of Representative

DATE: \_\_\_\_\_

Bid Number: 23-33      Bid Name: BOILER REPLACEMENT AT THE JEFFERSON COUNTY  
HUMAN SERVICES BUILDING

Attachment  
Certification Pursuant to Section 103-g  
of the New York State  
General Municipal Law

- A. By submission of this bid, each Bidder and each person signing on behalf of any Bidder certifies, and in the case of a joint bid, each party thereto certifies as to its own organization, under penalty of perjury, that to the best of its knowledge and belief that each Bidder is not on the list created pursuant to paragraph (b) of subdivision 3 of Section 165-a of the New York State Finance Law.
- B. A Bid shall not be considered for award, nor shall any award be made where the condition set forth in Paragraph A above has not been complied with; provided, however, that in any case the Bidder cannot make the foregoing certification set forth in Paragraph A above, the Bidder shall so state and shall furnish with the bid a signed statement which sets forth in detail the reasons therefore. Where Paragraph A above cannot be complied with, the Purchasing Unit to the political subdivision, public department, agency or official thereof to whom the bid is made, or his designee, may award a bid, on a case by case basis under the following circumstances:
1. The investment activities in Iran were made before April 12, 2012, the investment activities in Iran have not been expanded or renewed after April 12, 2012, and the Bidder has adopted, publicized and is implementing a formal plan to cease the investment activities in Iran and to refrain from engaging in any new investments in Iran; or
  2. The political subdivision makes a determination that the goods or services are necessary for the political subdivision to perform its functions and that, absent such an exemption, the political subdivision would be unable to obtain the goods and services for which the contract is offered. Such a determination shall be made in writing and shall be a public document.

\_\_\_\_\_  
Signature

\_\_\_\_\_  
Title

\_\_\_\_\_  
Date

\_\_\_\_\_  
Company Name

19HE

**Smith**  
CAST IRON BOILERS

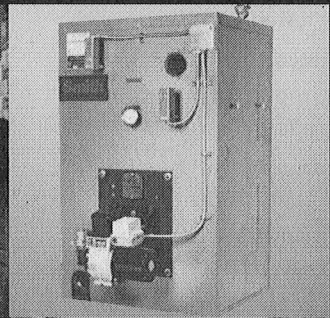
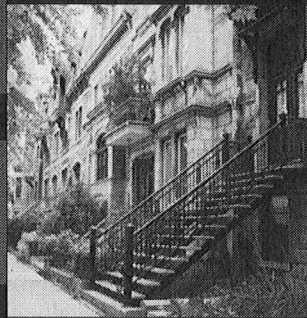

**series 19HE**

PRESSURIZED WET BASE  
BOILER/BURNER UNIT





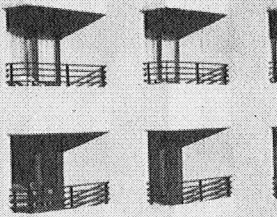

# series 19HE

Smith 19HE Series cast iron, pressurized, wet-base boiler/burner units are ideal for light commercial water or steam heating systems utilizing No. 2 fuel oil, natural gas, or combination gas/oil. Ten different sizes are available, ranging from 308 MBH I=B=R gross output units to 1750 MBH I=B=R gross output units. Series 19HE boilers are available in three ways — knocked down, assembled sections, or completely packaged units. All sections are tested and approved for 80 psi working pressure as standard equipment.

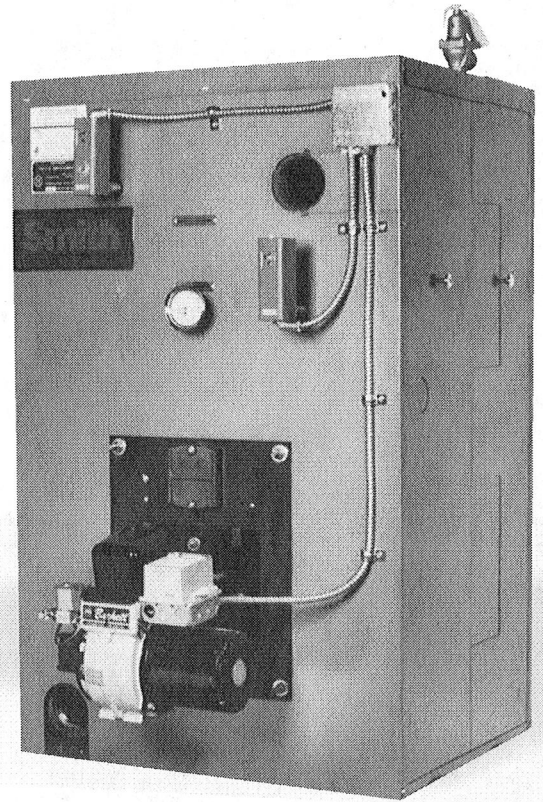

## STANDARD EQUIPMENT

### All Boilers

- Cast iron wet-base sections tested for 80psi.
- Insulated metal jacket
- Cast iron smokehood with integral damper
- Burner mounting plate with insulation block
- Front and rear flame observation ports
- Steel angle floor rails
- Hi-Temp hydronic port seals
- Flue brush
- Target Wall (3-6 sections)

### Water Boiler/Burner Units

- ASME relief valve, 40 psi
- Theraltimeter
- Manual reset, Hi-Limit control
- Lo-Limit operating control

### Steam Boiler/Burner Units

- ASME side outlet safety valve, 15 psi
- Steam gauge (0-30 psig)
- Gauge glass with gauge cocks and guards
- Manual reset, Hi-Limit control
- Lo-Limit operating control

*All sizes exceed the Ashrae 90.1 efficiency requirements*

## Designed and Constructed for Easy Service and Long Life.

19HE Series boiler/burner units are designed and constructed for easy service. A front observation port allows the serviceman to visually check the flame and combustion area. Easy-to-remove, side-mounted cover plates make boiler clean-out quick and easy. Side-mounted tankless 9 GPM coils allow for easy visual inspection and service. Heavy-duty, hydrocarbon-resistant Viton port seal gaskets are exceptionally easy to install. The integral, cast-iron, fail-safe breeching damper may be easily adjusted and securely locked in position. Individual section draw rods simplify assembly while reducing stress.

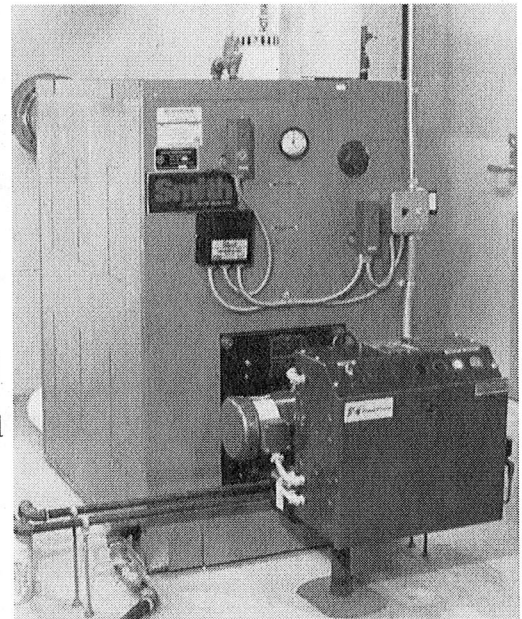

### Reliable, Fuel-Efficient Heat

Smith 19HE Series boiler/burner units are designed and constructed for high efficiency and superior performance. High-quality cast iron sections, cast-in heat extraction pins, completely insulated metal jacket, ceramic fiber rope section seals, obround-shaped upper ports, and carefully selected, high-efficiency burner add up to a boiler/burner unit that will provide reliable, fuel-efficient heat for years to come.

Compare Smith 19HE Series units with other brands with similar capacities — you'll discover that Smith is your smartest choice.

# PRESSURIZED WET-BASE BOILER BURNER UNITS ATTACHMENT A

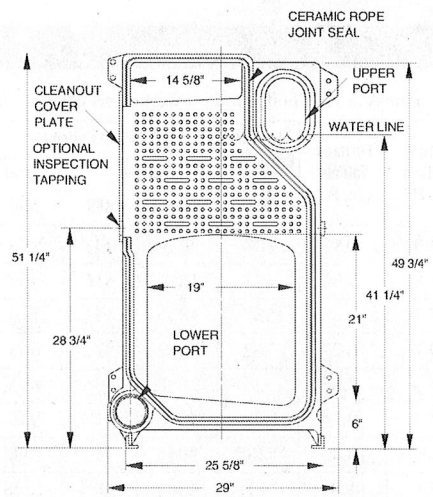
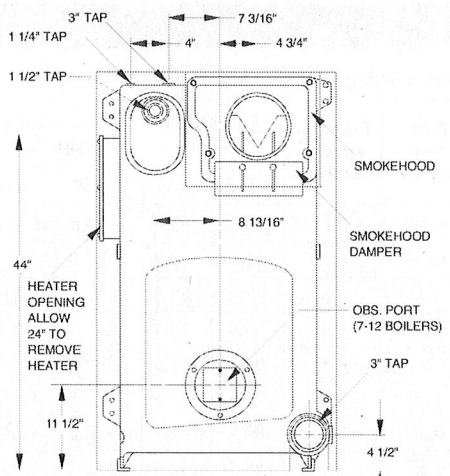
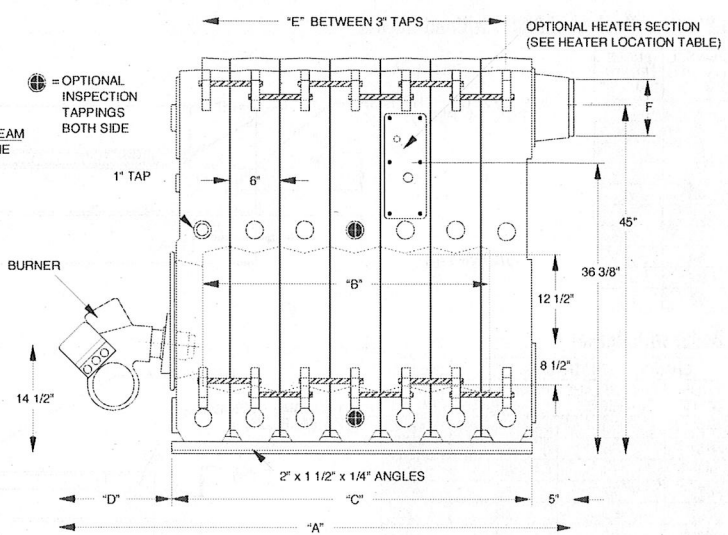
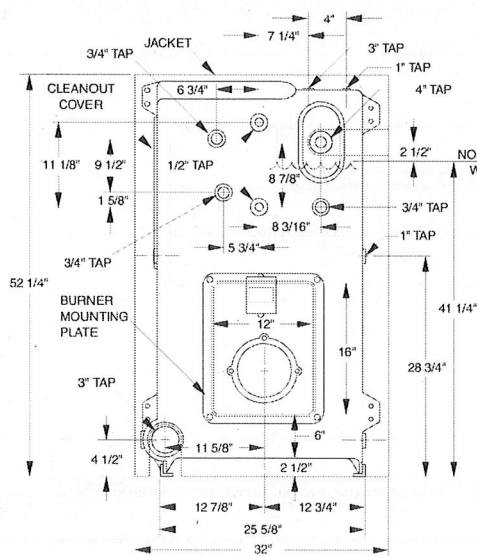

Dimensions (inches)												
Boiler Number	Overall Length "A"				"B"	"C"	Burner Length "D"				"E" Distance Between Supply Tappings	"F" Flue Pipe Diameter
	Carlin	PF/J	PF/C	Beckett Oil			Carlin	PF/J	PF/C	Beckett Oil		
†19HE-3	39	44	-	31	9	18	16	21	-	13	12	7
†19HE-4	45	50	59	37	15	24	16	21	30	13	18	7
†19HE-5	51	56	65	43	21	30	16	21	30	13	24	8
†19HE-6	61	62	71	49	27	36	20	21	30	13	30	8
†19HE-7	67	68	82	64	33	42	20	21	35	22	36	9
†19HE-8	73	74	88	71	39	48	20	21	35	23	42	10
†19HE-9	79	80	94	77	45	54	20	21	35	23	48	10
†19HE-10	87	86	100	83	51	60	22	21	35	23	54	10
†19HE-11	93	-	106	89	57	66	22	-	35	23	60	10+
†19HE-12	99	-	112	99	63	72	22	-	35	27	66	10+

The manufacturer should be consulted before selecting a boiler for installations having unusual piping and pickup requirements, such as intermittent system operation, extensive piping, etc. For forced hot water heating systems where the boiler and all piping are within the area to be heated, the boiler may be selected on the basis of its Gross Output.

+ 11 and 12 section requires 12" diameter vent pipe. Transition collar provided by Smith.  
**NOTE: Dimensions are approximate. Should not be used to "rough-in" equipment.**



Assembled Block or Packaged Boiler without Burner

NO. OF SECTIONS	CHANNEL LENGTH DIM. "A"	ANGLE LENGTH DIM. "B"
3	39	18
4	45	24
5	51	30
6	57	36
7	63	42
8	69	48
9	75	54
10	81	60
11	87	66
12	93	72

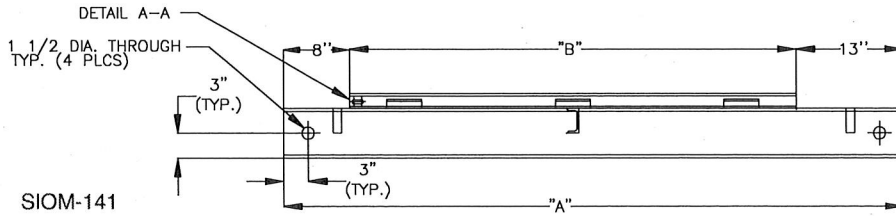

Packaged Boiler with Burner

NO. OF SECTIONS	CHANNEL LENGTH DIM. "A"			ANGLE LENGTH DIM. "B"
	CARLIN/BECKETT J-SERIES	POWERFLAME C-SERIES	POWERFLAME J-SERIES	
3	49	59	59	18
4	55	65	65	24
5	61	71	71	30
6	67	77	77	36
7	78	83	83	42
8	84	89	89	48
9	90	95	95	54
10	99	101	101	60
11	105	107	107	66
12	111	113	113	72

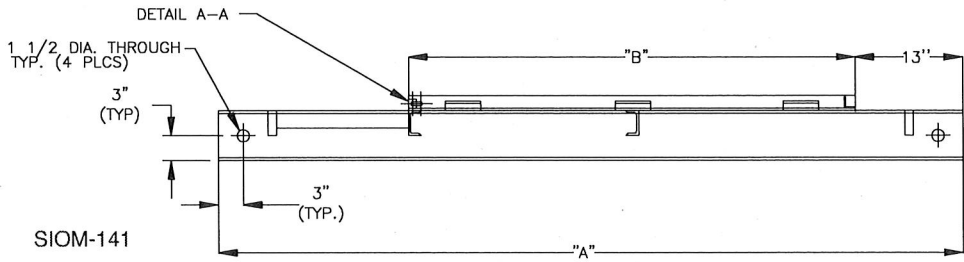

I B R Ratings, Burner Capacities

Designed and tested to the A.S.M.E. boiler and pressure vessel code, section IV for maximum allowable working pressure, steam 15 psig, water 80 psig.

Boiler Number	Boiler Horsepower	Heating Surface (Sq. Ft.)	Furnace Volume (Cu. Ft.)	I=B=R Gross Output (MBH)	Net I=B=R Rating (1)			I=B=R Burner Capacity		Draft Loss (in W.C.)	Overfire(4) Pressure (in W.C.)	Water Content (Gals.)		Water Working Weight (Lbs.)	
					Steam		Water	OilGPH(2)	GasMBH(3)			Steam	Water	Steam	Water
					(Sq. Ft.)	MBH	MBH								
†19HE*-3	9.2	23.9	2.12	308	963	231	268	2.60	375	0.18	0.28	33.2	38.6	1673.6	1716.8
†19HE*-4	12.5	35.8	3.50	421	1316	316	369	3.60	520	0.18	0.28	41.1	49.2	2057.8	2122.6
†19HE*-5	17.5	47.7	4.88	587	1835	441	510	5.00	725	0.20	0.30	49.0	59.8	2442.0	2528.4
†19HE*-6	22.8	59.7	6.27	762	2382	572	663	6.50	931	0.23	0.33	56.8	70.3	2825.4	2933.4
†19HE*-7	27.6	71.6	7.65	924	2888	694	803	7.90	1137	0.26	0.36	64.7	80.9	3209.6	3339.2
†19HE*-8	32.5	83.5	9.04	1087	3398	817	945	9.30	1342	0.29	0.39	72.6	91.5	3593.8	3745.0
†19HE*-9	37.7	95.4	10.42	1262	3945	947	1087	10.80	1548	0.32	0.42	80.5	102.0	3978.0	4150.0
†19HE*-10	42.5	107.4	11.81	1424	4504	1081	1238	12.20	1754	0.35	0.45	88.3	112.6	4361.4	4555.8
†19HE*-11	47.4	119.3	13.20	1587	5071	1217	1380	13.60	1989	0.38	0.48	96.2	123.1	4745.6	4960.8
†19HE*-12	52.3	131.2	14.58	1750	5633	1352	1522	15.00	2165	0.41	0.51	104.0	133.7	5129.0	5366.6

† No insert for oil. Insert prefix "G" for gas or "GO" for combination gas/oil.  
 \* Insert "S" for steam, "W" for water. Example: GO19A-S-10 is a 10-section 19A Series Boiler for steam using combination gas/oil burner.

- (1) The net I=B=R Steam Ratings shown are based on a piping and pickup allowance of 1.333. The I=B=R Water Ratings shown are based on an allowance of 1.15.
- (2) Based on light oil having a heat content of 140,000 BTU per gallon.
- (3) Gas having a heat content of 1,000 BTU/cu. ft. at 0.6 specific gravity.
- (4) Includes 0.10" W.C. pressure on upstream side of exit damper.

Side-Mounted Tankless Heater Capacities

No. of Sections	I=B=R Gross Output MBH	Cont. Draw (GPM)		
		One Heater	Two Heaters	Three Heaters
3	308	8.5	N/A	N/A
4	421	8.5	N/A	N/A
5	587	9.0	10.6	N/A
6	762	9.0	12.9	N/A
7	924	9.0	15.3	N/A
8	1087	9.0	17.6	N/A
9	1262	9.0	18.0	19.9
10	1424	9.0	18.0	22.2
11	1587	9.0	18.0	24.6
12	1750	9.0	18.0	26.9

Heater ratings based on 100° F temperature rise, 200° F boiler water, 9 GPM at 9.5 psi ∅ P. For 180° boiler water ratings, consult factory.

Heater Section Location

Boiler Number	Max. No. of heaters	Location by boiler section (Heaters install from right side)
19HE-3	1	F - <b>H</b> - B
19HE-4	1	F - P - <b>H</b> - B
19HE-5	2	F - <b>H</b> - P - <b>H</b> - B
19HE-6	2	F - P - <b>H</b> - P - <b>H</b> - B
19HE-7	3	F - <b>H</b> - P - <b>H</b> - P - <b>H</b> - B
19HE-8	3	F - P - <b>H</b> - P - <b>H</b> - P - <b>H</b> - B
19HE-9	3	F - P - <b>H</b> - P - <b>H</b> - P - <b>H</b> - P - B
19HE-10	3	F - P - P - P - P - P - P - P - B
19HE-11	3	F - P - P - P - <b>H</b> - P - <b>H</b> - P - <b>H</b> - P - B
19HE-12	3	F - P - P - P - P - <b>H</b> - P - <b>H</b> - P - <b>H</b> - P - B

F = Front, P = Intermediate Plain, **H** = Intermediate Heater, B = Back

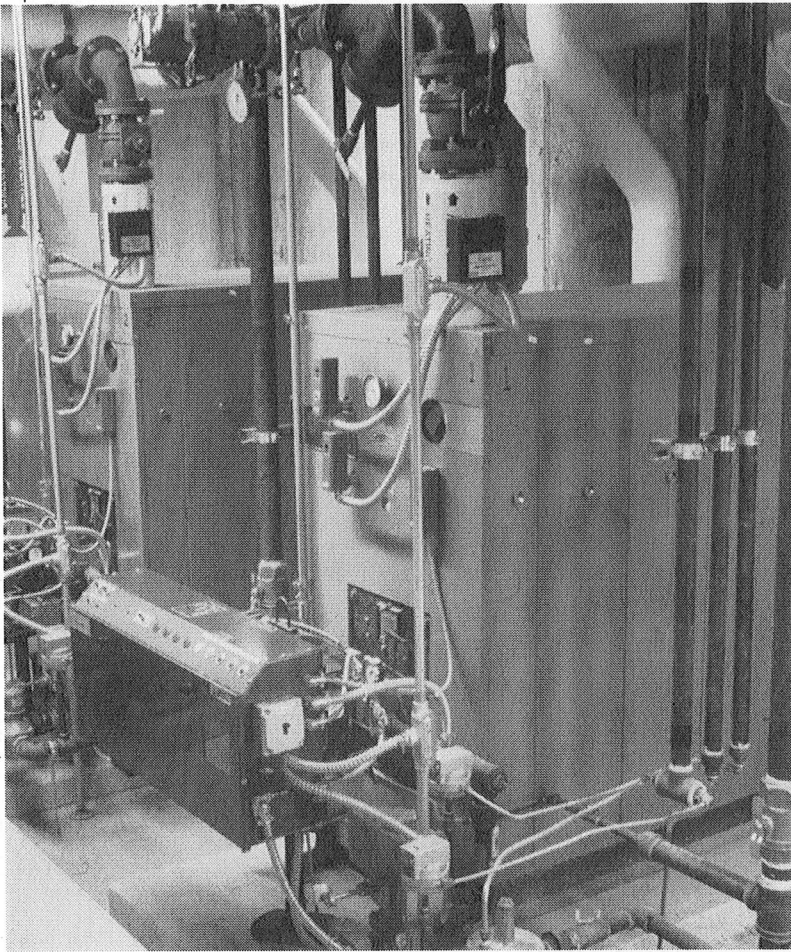

## Burners:

### Carlin Light Oil Burner

- High performance, forced draft, UL listed, flame retention oil burner:
  - On-off firing, (4 thru 5 sections), with cadmium cell primary control, oil valve, delay timer. Lo-hi firing (6 thru 12 sections)
  - Single stage fuel unit (3 thru 5 sections)
  - Two stage fuel unit (6 thru 12 sections)

### Beckett Light Oil Burner

- High performance, forced draft, UL listed, flame retention oil burner:
  - On-off firing, (3 thru 5 sections) with cadmium cell primary control, oil valve. Lo-hi off firing (6 thru 12 sections)
  - Single stage fuel unit (3 and 4 sections)
  - Two stage fuel unit (5 thru 12 sections)

### → Power Flame Gas Burner

- High performance, forced draft, UL listed, power gas burner for natural gas firing:
  - On-off firing, (3 thru 12 sections), fixed air shutter combustion control, 115 volt diaphragm gas shut-off valve, 115 volt solenoid auxiliary gas valve, spark ignited intermittent gas pilot (gas train not assembled), pilot gas train with solenoid valve, pressure regulator and manual shut-off cock, pilot tubing and fittings

### Power Flame Gas/Oil Burner

- Both fuels — Spark ignited gas pilot, intermittent UV flame detection, prepurge.
  - On-off firing (4 thru 12 sections), with fixed air shutter, two stage fuel pump for oil, oil valve, slow opening diaphragm gas valve for gas, auxiliary solenoid gas valve. Gas train not assembled
  - Pilot gas train with solenoid valve, pressure regulator and manual shut-off cock, pilot tubing and fittings



# series 19HE

## OPTIONAL EQUIPMENT

### All Boilers

- Tankless water heaters
- Heater cover plates
- Sections assembled
- Packaged
- Burner start-up and one-year service
- Low water cutoffs
- Feeder and pump controllers
- Inspection taps and brass plugs (up to four per section)
- Water boilers—80 psi pressure relief valve

### Beckett & Carlin Oil Burners

- Electronic controls
- Two stage fuel unit (4 thru 6 sections)
- N.Y.C.— D.E.P. (formerly B.A.R.) approval
- Burner mounted, factory wired control panel
- Lo-hi-lo firing (7 thru 12 sections)

### Power Flame Gas and Oil Burners

- Two stage firing with fuel-air control
- Lo-hi-lo firing
- Modulating firing
- I.R.L., FM, MASS approval
- Other motor current characteristics
- Increased gas train sizes for low pressure drops
- Flame safeguard options

Burner Models											
No. of Boiler Sections	Carlin Oil	HP	Beckett Oil	HP	Power Flame						
					Oil	HP	Gas	HP	Gas/Oil	HP	
					3	201CRD	—	CF500	1/3	—	—
4	301CRD	1/4	CF500	1/3	CR1-0	1/3	JR15A	1/4	CR1-GO	1/3	
5	301CRD	1/4	CF800	1/3	CR1-0	1/3	JR30A	1/4	CR1-GO	1/3	
6	702CRD	1/2	CF1400	1/2	CR1-0	1/2	JR30A	1/3	CR1-GO	1/3	
7	702CRD	1/2	CF1400	1/2	CR2-0	3/4	JR30A	1/3	CR2-GO	3/4	
8	702CRD	1/2	N/A	N/A	CR2-0	3/4	JR50A	1/3	CR2-GO	3/4	
9	702CRD	1/2	CF2300	3/4	CR2-0	3/4	JR50A	1/3	CR2-GO	3/4	
10	801CRD	3/4	CF2300	3/4	CR2-0	3/4	JR50A	1/3	CR2-GO	3/4	
11	801CRD	3/4	CF2500	2	CR2-0	1	CR2G	1/2	CR2-GO	3/4	
12	801CRD	3/4	CF2500	2	CR2-0	1 1/2	CR2G	1/2	CR2-GO	3/4	



MEA #416-99-M

In the interest of product development, we reserve the right to make changes without notice.

**Smith**  
CAST IRON BOILERS

Westcast, Inc., 260 North Elm Street, Westfield, MA 01085

(413) 562-9631 • FAX: (413) 562-3799

www.smithboiler.com

◆ A MESTEK COMPANY

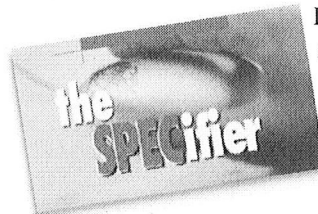

Log on to [www.smithboiler.com](http://www.smithboiler.com) and get connected to the Smith Heating Pros SPECifier. Fast, browser-based, easy-to-use program provides dynamically generated specifications, Auto-Cad drawings and more for Smith commercial boilers.